

HERITAGE CLASSIC RANGE FEATURES



LARGEST OVEN CAPACITY IN THE INDUSTRY
Our 30" and 36" range ovens can easily accommodate a full size commercial sheet pan.

Oven capacity: 18" oven - 2.7 cu. ft. 30" oven - 4.9 cu. ft.
24" oven - 3.8 cu. ft. 36" oven - 6.0 cu. ft.



INNOVECTION® OVEN TECHNOLOGY

Innovation® Convection with its dual fan system, optimizes uniform air flow and a balances turbulent heat distribution when baking, roasting and dehydrating food, reducing cooking time, reducing gas usage, and delivering superior product.



HEAVY DUTY KNOBS

Solid die cast heavy duty satin finish black knobs set in a chrome plated bezel with LED indicator lights for each knob, illuminate when burners are on. Knobs also available as an option in Red or Burgundy.



RAPID HEAT OUTPUT

Rapid heat output and superior heat distribution boils water; sautes and cooks your favorite dishes, while reducing cooking time.
3 sizes of burners to serve your everyday needs.



LIFT OFF BURNERS

Spills happen. Our stainless steel sealed cooktop contains more than a gallon of liquid spills. Burner caps and rings lift off for easy cleaning and are dishwasher safe.

HERITAGE CLASSIC SERIES

SEALED BURNER FREESTANDING GAS RANGES



24"

Heritage Classic range with 4 sealed gas burners, 24" Innovection® oven with Inconel® infrared broiler. Shown with optional leg caps & 4" riser.

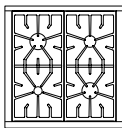

ARR-244



30"

Heritage Classic range with 4 sealed gas burners, 30" Innovection® oven with Inconel® infrared broiler. Shown with optional leg caps & 4" riser.

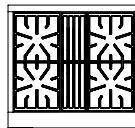

ARR-304



36"

Heritage Classic range with 6 sealed gas burners, 36" Innovection® oven with Inconel® infrared broiler. Shown with optional leg caps & 4" riser.

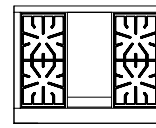

ARR-364GD

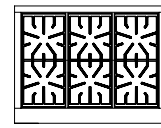

ARR-366

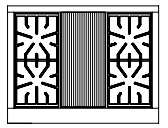

ARR-364GR



COMMERCIAL GRADE INCONEL® BROILER BURNER
Constructed from Inconel® stainless steel a superior alloy developed to withstand high heat and abuse, the 16,000 BTU infrared burner delivers broiling temperatures up to 1,800°F perfect for searing steak, fish or any food of your choice. This respective burner is utilized in our commercial products.



RAPID HEAT OUTPUT
Rapid heat output and superior heat distribution boils water, sautes and cooks your favorite dishes, while reducing cooking time.

3 sizes of burners serve your everyday needs:

Large burner:	17,000 BTU
Medium burner:	13,000 BTU
Small burner:	9,000 BTU

HERITAGE CLASSIC SERIES

SEALED BURNER FREESTANDING GAS RANGES



48"

Heritage Classic range with 4 sealed gas burners with 22" griddle, 18" & 30" Innovection® ovens with Inconel® infrared broiler in each oven. 18" oven is a fully functional bake and convection oven. Shown with optional leg caps & 4" riser.

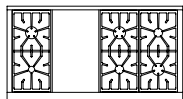

ARR - 486GD

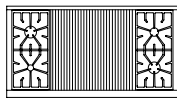

ARR - 484X2GR

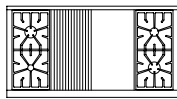

ARR - 484GDGR

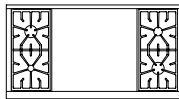

ARR - 4842GD

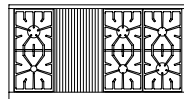

ARR - 486GR



60"

Heritage Classic range with 6 sealed gas burners with 11" wide grill and 11" wide griddle (2) 30" Innovection® ovens with Inconel® infrared broiler in each oven. Shown with optional leg caps & 4" riser.

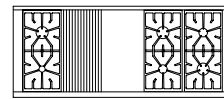

ARR - 606GDGR

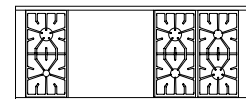

ARR - 6062GD

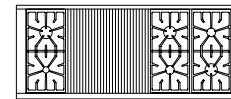

ARR - 606X2GR



MIRROR CHROME GRIDDLES (UPGRADE OPTION)

Our new mirror chrome griddle finish is a shining example of our commitment to cooking innovation. Four models to choose from – flat, half-flat-half-grooved with flavor separator, and all-grooved, to help the discerning chef prepare dishes with restaurant-style look and flavor in the comfort of your own kitchen.



LARGEST CAPACITY OVENS IN THE MARKET

Our 30", 36" 48" & 60" range ovens easily accommodate commercial full size sheet pans.

Our offering of maximum capacity ovens:
 18" oven - 2.7 cu. ft.
 24" oven - 3.8 cu. ft.
 30" oven - 4.9 cu. ft.
 36" oven - 6.0 cu. ft.

Largest oven capacity in the industry 13

HERITAGE CLASSIC SERIES
 GAS RANGES WITH SEALED BURNERS, INNOVECTION® OVEN AND INFRARED BROILER

24" FREESTANDING ALL GAS RANGE WITH SEALED BURNERS	
Overall Oven Capacity	3.8 CU. FT.
Oven Dimensions	20 -1/2"W x 20 -1/2" D x 15 -1/2" H
Surface Burner Rating	17,000 BTU (lg) - 13,000 BTU (md) - 9,000 BTU (sm)
Infrared Broiler	18,000 BTU
Oven Bake Burner	30,000 BTU
Total Gas Connection Rating per model #	ARR-244 104,000 BTU 4 burners
Gas Supply	7" W.C. Natural, 11" W.C. Propane
Electrical Supply	120 VAC 15 AMP 60 Hz Single Phase
Shipping Weight	340 Lbs

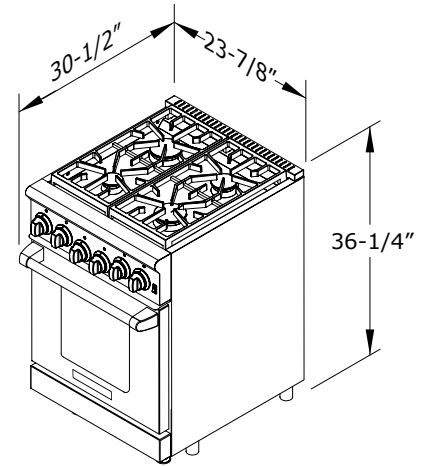

30" FREESTANDING ALL GAS RANGE WITH SEALED BURNERS	
Overall Oven Capacity	4.9 CU. FT.
Oven Dimensions	26 -1/2"W x 20 -1/2" D x 15 -1/2" H
Surface Burner Rating	17,000 BTU (lg) - 13,000 BTU (md) - 9,000 BTU (sm)
Infrared Broiler	18,000 BTU
Oven Bake Burner	30,000 BTU
Total Gas Connection Rating per model #	ARR-304 104,000 BTU 4 burners
Gas Supply	7" W.C. Natural, 11" W.C. Propane
Electrical Supply	120 VAC 15 AMP 60 Hz Single Phase
Shipping Weight	407 Lbs

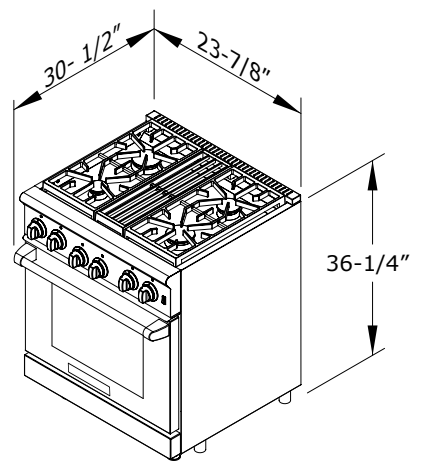

36" FREESTANDING ALL GAS RANGES WITH SEALED BURNERS	
Overall Oven Capacity	6.0 CU. FT.
Oven Dimensions	32 -1/2"W x 20 -1/2" D x 15 -1/2" H
Surface Burner Rating	17,000 BTU (lg) - 13,000 BTU (md) - 9,000 BTU (sm)
Griddle Burner Rating	20,000 BTU
Grill Burner Rating	18,000 BTU for every 11" section
Infrared Broiler	18,000 BTU for every 11" section
Oven Bake Burner	30,000 BTU
Total Gas Connection Rating per model #	ARR-366 134,000 BTU 6 burners ARR-364GD 124,000 BTU 4 burners and griddle ARR-364GR 122,000 BTU 4 burners and grill
Gas Supply	7" W.C. Natural, 11" W.C. Propane
Electrical Supply	120 VAC 15 AMP 60 Hz Single Phase
Shipping Weight	440 Lbs

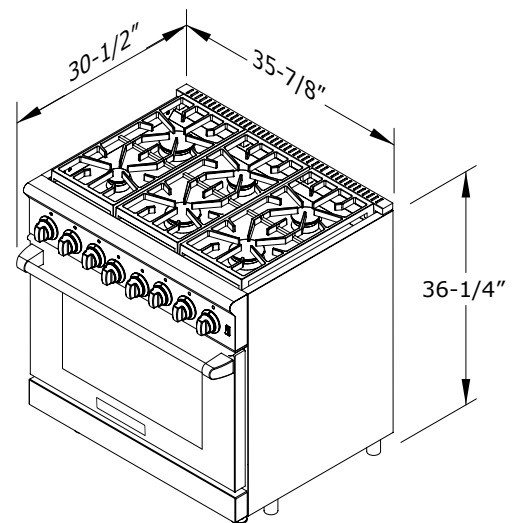

ACCESSORIES	30"	36"	ACCESSORIES	30"	36"
Island Back (Standard)	ARR-30SIB-H	ARR-36SIB-H	12" Grill Cover	N/A	ARR-GRCOV12-H
Island Back (Welded)	ARR-30IB-H	ARR-36IB-H	12" Griddle Cover	N/A	ARR-GDCOV12-S-H
4" Stub Back	ARR-304SB-H	ARR-364SB-H	12" Removable Griddle Plate	N/A	ARR-PGPI2 -H
20" High Back with Shelf	ARR-3021HBS-H	ARR-3621HBS-H	Cutting Board	ARR-CUTB-12-C	ARR-CUTB-12-H
Curb Base	ARR-30CB-H	ARR-36CB-H	Wok Adapter	ARR-WOK-C	ARR-WOK-H
Leg Caps (set of 2)	ARR-2LC-H	ARR-2LC-H			

HERITAGE CLASSIC SERIES
 GAS RANGES WITH SEALED BURNERS, INNOVECTION® OVEN AND INFRARED BROILER

48" FREESTANDING ALL GAS RANGES WITH SEALED BURNERS	
Overall Oven Capacity	2.7 CU. FT. (18" oven) - 4.9 CU. FT. (30" oven)
Oven Dimensions	14 -1/2"W x 20 -1/2" D x 15 -1/2" H (18" oven) 26 -1/2"W x 20 -1/2" D x 15 -1/2" H (30" oven)
Surface Burner Rating	17,000 BTU (lg) - 13,000 BTU (md) - 9,000 BTU (sm)
Griddle Burner Rating	20,000 BTU for every 11" section
Grill Burner Rating	18,000 BTU for every 11" section
Infrared Broiler	18,000 BTU each oven
Oven Bake Burner	30,000 BTU each oven
Total Gas Connection Rating per model #	ARR-486GD 190,000 BTU 6 burners and griddle ARR-486GR 188,000 BTU 6 burners and grill ARR-484GDGR 178,000 BTU 4 burners, griddle and grill ARR-4842GD 180,000 BTU 4 burners double griddle ARR-484X2GR 176,000 BTU 4 burners double grill
Gas Supply	7" W.C. Natural, 11" W.C. Propane
Electrical Supply	120 VAC 15 AMP 60 Hz Single Phase
Shipping Weight	660 Lbs

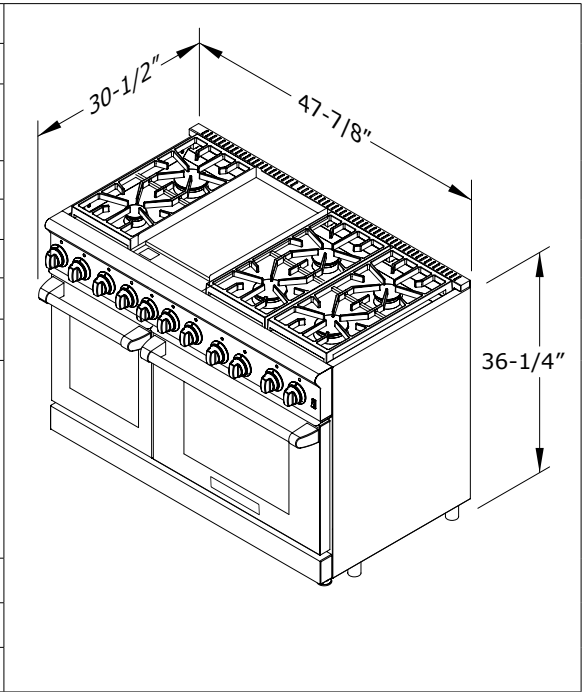

60" FREESTANDING ALL GAS RANGES WITH SEALED BURNERS	
Overall Oven Capacity	4.9 CU. FT. each oven
Oven Dimensions	26 -1/2"W x 20 -1/2" D x 15 -1/2" H" each oven
Surface Burner Rating	9,000 BTU (sm), 13,000 BTU (md), 17,000 BTU (lg)
Griddle Burner Rating	20,000 BTU per every 11" section
Grill Burner Rating	18,000 BTU per every 11" section
Infrared Broiler	18,000 BTU each oven
Oven Bake Burner	30,000 BTU each oven
Total Gas Connection Rating per model #	ARR-606GDGR 220,000 BTU 6 burners, griddle and grill ARR-6062GD 222,000 BTU 6 burners and double griddle ARR-606X2GR 218,000 BTU 6 burner and double grill
Gas Supply	7" W.C. Natural, 11" W.C. Propane
Electrical Supply	120 VAC 15 AMP 60 Hz Single Phase
Shipping Weight	780 Lbs

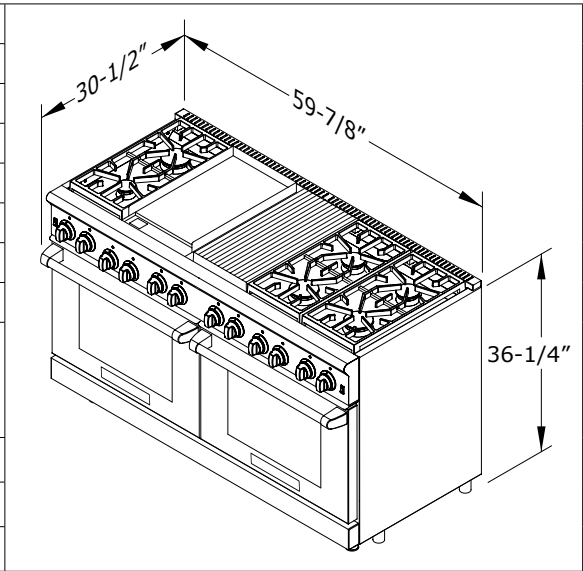

ACCESSORIES	48"	60"	ACCESSORIES	48"	60"
Island Back (Standard)	ARR-48SIB-H	ARR-60SIB-H	12" Grill Cover	ARR-GRCOV12-H	ARR-GRCOV12-H
Island Back (Welded)	ARR-48IB-H	ARR-60IB-H	12" Griddle Cover	ARR-GDCOV12-S-H	ARR-GDCOV12-S-H
4" Stub Back	ARR-484SB-H	ARR-604SB-H	24" Griddle Cover	ARR-GDCOV24-S-H	ARR-GDCOV24-S-H
20" High Back with Shelf	ARR-4821HBS-H	ARR-6021HBS-H	12" Removable Griddle Plate	ARR-PGP12-H	ARR-PGP12-H
Curb Base	ARR-48CB-H	ARR-36CB-H	Cutting Board	ARR-CUTB-12-H	ARR-CUTB-12-H
Leg Caps (set of 2)	ARR-2LC-H	ARR-2LC-H	Wok Adapter	ARR-WOK-H	ARR-WOK-H

N= Natural Gas Must provide **N** or **L** after model for type of gas needed.
L = LP Gas Example: AROFG-30**L**, represents unit to be built for LP gas.
 Must specify elevation if over 1,000 ft. when ordering.