

# AMERICAN

## PROFESSIONAL RANGES

### 60" Residential Range

#### Commercial Heritage

Over the past 30 years, American Range has earned its workplace pedigree in the world's most demanding kitchens. In that time, innovative technology and robust engineering have advanced every aspect of our cooking equipment. We proudly introduce the new standard in professional home ranges, **American™**.

American Range introduces the new gas range for the home with the arrival of our innovative commercial convection baking technology, **Innovection™**.

A refined eye for luxury and an obsessive attention to the smallest of details have established the **American™** series of home ranges, to be the professional chefs' choice for work and now also for the home.

#### Commercial Grade

Our professional ranges have the soul, capability, and durability of our commercial ranges blended with advanced engineering and luxurious style. To summarize, we have taken our successful commercial range and "**civilized**" it for the home.



ARR-6064R4D1



#### Introducing the Innovection™ Convection Oven Technology

American Range is pleased to introduce **Innovection™** Convection Oven Technology. Utilized in our commercial convection ovens, the American Range **Innovection™** oven cavity is designed with louvered side panels and dual convection motors. The innovative design distributes turbulent warm air throughout the large oven cavity, and is instrumental for consistent even baking, while saving time and gas.

#### Largest Cooking Capacity

American Range is proud to introduce the largest oven cavities ((2) 30" ovens both @ 4.8 cu. ft.) in the industry. Each oven allows for cooking on all six oven rack positions simultaneously. Baking six trays of tarts, cookies, or hour' devours on commercial size sheet pans (18" x 26") is possible without the worry of burning the top row, having a doughy middle row, or a singed bottom row. Imagine completing six batches within one baking cycle!

# 60" RESIDENTIAL RANGE

## STANDARD FEATURES

- **Innovection™ Convection System** – utilizing dual convection motors which provide superior baking performance

## Oven Functions

- Convection Bake, Dehydrate and Defrost
- Standard Bake and Broil
- (2) 30" ovens; both ovens comprise the industry's largest oven cavities at 4.8 cu. ft.
- 30,000 BTU hidden bake oven burner
- 15,500 BTU **Inconel®** banquet broiler burner produces 1,500°F broiling temperatures
- Commercial grade stainless steel construction and insulation
- Commercial grade high temperature porcelain oven interior
- Two oven lights
- 2 oven racks with 6 rack positions

## Range Top

- (3) 17,000 BTU sealed burners, (2) 13,000 BTU sealed burners and (1) 9,000 BTU sealed burner
- All burners simmer at 140°F, with infinite setting controls.
- ARR-6062GDI (3) 17,000 BTU, (2) 13,000 BTU, (1) 9,000 BTU sealed burners with (1) 24" 20,000 BTU griddle
- ARR-6062GRI (3) 17,000 BTU, (2) 13,000 BTU, (1) 9,000 BTU sealed burners with (1) 24" 15,000 BTU grill
- ARR-606GDRI (3) 17,000 BTU, (2) 13,000 BTU, (1) 9,000 BTU sealed burners with (1) 12" 15,000 BTU grill, (1) 12" 20,000 BTU griddle
- Sealed burners simmer at 140°F, all with infinite setting controls
- Sealed, one-piece, stainless steel burner top surface
- Child safe push-and-turn top burner controls
- All top burners have flame sensing reignition in the event the flame goes out
- Blue LED indicator lights for each burner
- Continuous and flush commercial grade grates allow for easy transferring of pots and pans across the entire cooking surface
- 4" Riser

## Innovection™ Convection Oven Technology

Even, turbulent heat distribution is essential when baking, roasting, and dehydrating food. The American Range **Innovection™** convection oven technology utilizes dual convection motors and louvered side panels to enhance uniform heat distribution throughout the large oven cavity. The strategic placement of the dual **Innovection™** convection motors blended with the innovative louvered side panel design ensures consistent heat distribution; even when challenged with cooking the largest turkey, ham or roast.

The results are remarkable! Faster baking and roasting time with fabulous results. If you love to bake, our **Innovection™** technology is for you.



**Innovection™ Heat Pattern**

## ACCESSORIES

- Leg Cap (Set of Two)
- Back Splash
- Cover Grill
- Back Splash 20" Island
- Back Splash 20" Island with Shelf
- Back Splash 20" Island without Shelf
- Back Splash Island
- Cutting Board
- Cover Griddle
- Griddle Plate
- Wok Ring

## ELECTRICAL REQUIREMENTS

- 120 VAC, 9 Amps, Single Phase

## OPERATING GAS PRESSURE

NAT: 5.0 inches WC  
LP: 10.0 inches WC

## WARRANTY

1 Year Parts and Labor

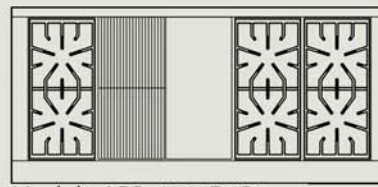

Model# ARR-6064D4R1

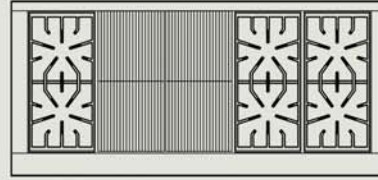

Model# ARR-6062GR1

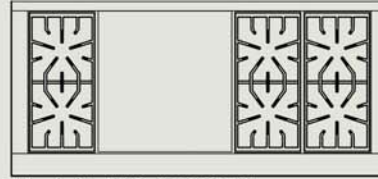

Model# ARR-6062GD1

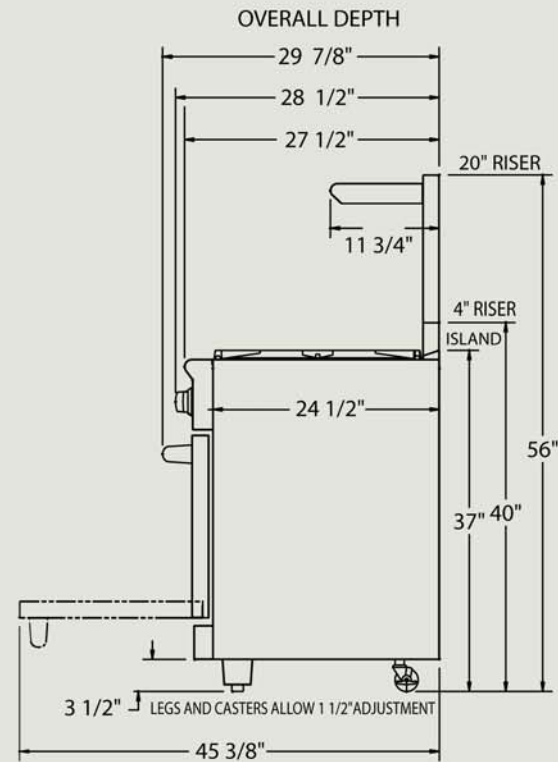
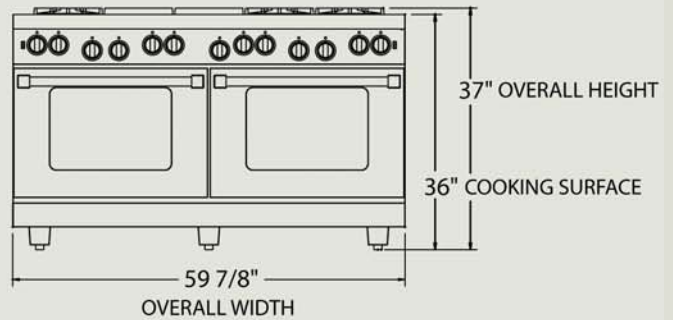

**AMERICAN**  
PROFESSIONAL RANGES

13592 Desmond St Pacoima CA 91331  
Tel 818.897.0808 Fax 818.897.1670  
Toll Free 888.753.9898  
www.americanrange.com